

COMPACT MOTOR - IVR 234 - 235 - 236 - 237



Valvola di zona a 3 vie deviatrice.

Le valvole a sfera della serie Compact Motor possono essere motorizzate mediante attacco diretto del servocomando sulla valvola. Il fissaggio del servocomando avviene mediante l'inserimento di una coppia in acciaio che ne permette l'installazione e lo smontaggio in modo semplice rapido e sicuro.
Impieghi: impianti di riscaldamento singoli o a zone, industriali in genere con fluidi caldi e freddi, automazione e irrigazione nelle serre.

3 ways diverter zone valve.

The Compact Motor ball valve series can be motorized by the actuator. The actuator is blocked to the valve with metallic spigot that allows to connect/unconnect the actuator in secure simple and rapid way.

Application: Heating installations, integrated or distinct zones, general industrial applications with the use of hot and cold fluids, automated irrigation for greenhouses

3-Wege-Ableitzoneventil.

Die Kugelhähne der Serie Compact Motor können mit Hilfe eines Stellmotors betrieben werden. Die Montage der Stellmotors erfolgt durch einfaches aufsetzen, dadurch ist eine schnelle und sichere Installation oder auch Demontage möglich.

Anwendung: Heizungssysteme und Zoneheizanlagen, Industrieanlagen mit warmer und kalter Flüssigkeit,, Automationsanlagen und Bewässerungsanlagen.

Vanne de zone à 3 voies déviateur

La vannes a boisseau sphérique serie Compact Motor peuvent etre motorisées à travers un branchement direct du servocommande sur la vanne. Le fixage du servocommande se fait avec l'insertion d'une goupille en acier inoxydable qui permet l'installation et démontage de façon simple, rapide et sûre.

Application: Installations de chauffage simples ou par zone, applications industrielles génériques avec fluides chauds ou froids, automation et irrigation dans les serres

трехходовый клапан распределитель.

Серия шаровых кранов Compact Motor может быть оснащена электроприводом. Привод крепится к корпусу крана с помощью металлической втулки, которая позволяет быстро и легко соединять и разъединять привод и кран.

Сфера применения: бытовые системы отопления целом а также и отдельные их зоны, промышленные системы с холодными и горячими жидкостями, системы автоматизации и орошения в теплицах.

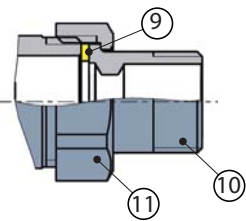
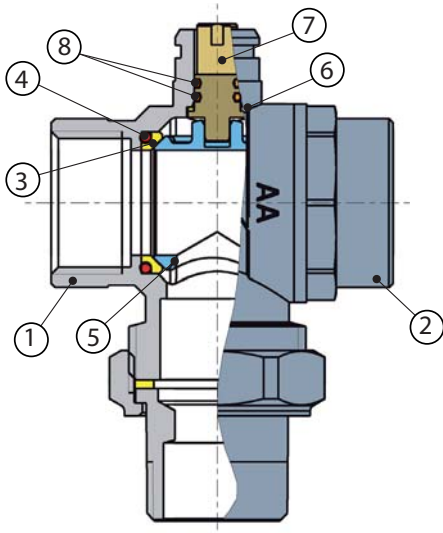

N	DENOMINAZIONE PART NAME	MATERIALE MATERIAL	TRATTAMENTO TREATMENT
1	Corpo - Body	Ottone - Brass CW617DW - UNI EN 2165/98	Nichelato - Nickel plated
2	Manicotto - Body end	Ottone - Brass CW617DW - UNI EN 2165/98	Nichelato - Nickel plated
3	Seggio - Seat	PTFE G200 - PTFE G200	
4	O-Ring - O-Ring	EPDM - EPDM	
5	Sfera - Ball	Ottone - Brass CW 617N - UNI EN 12165/98	Cromata - Chrome plated
6	Asta - Stem	Ottone - Brass CW614DW - UNI EN 12164/98	
7	Rodella - Washer	PTFE G200 - PTFE G200	
8	O-Ring - O-Ring	EPDM Perox - EPDM Perox	
9	Guarnizione - Seat	Fibra termoresistente Heat resisting fibre	
10	Codolo - Union	Ottone - Brass CW617DW - UNI EN 2165/98	Nichelato - Nickel plated
11	Calotta - Nut	Ottone - Brass CW617N - UNI EN 2165/98	Nichelato - Nickel plated

PRESSIONE / TEMPERATURA - PRESSURE / TEMPERATURE

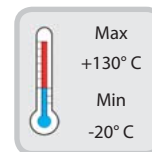
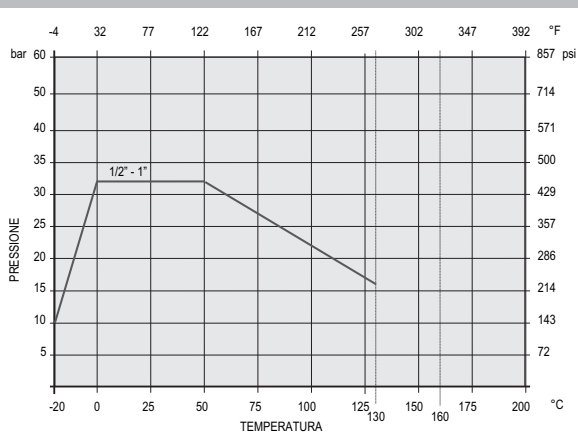

COMPACT MOTOR - IVR 234 - 235 - 236 - 237



PERDITE DI CARICO - FLOW AND PRESSURE DROPS

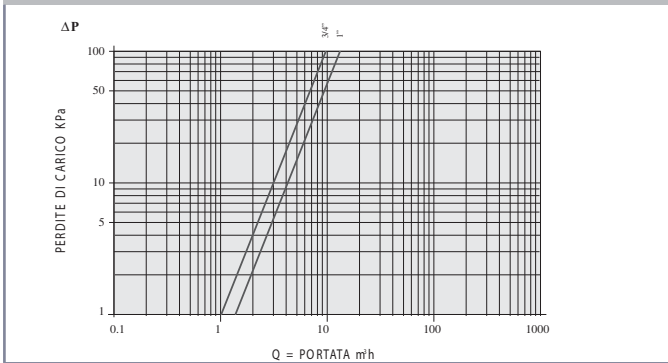

Misura - Size	KV
3/4" - 20	9.6
1" - 25	11.3

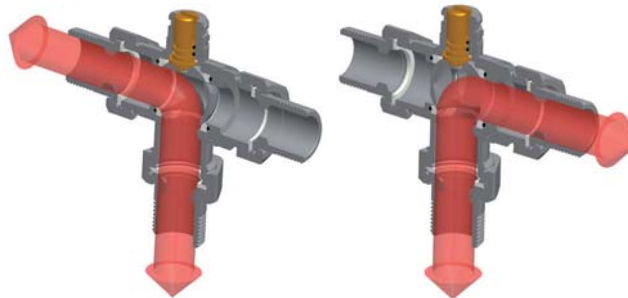

DIMENSIONI - DIMENSIONS (mm)

Size	Ø	F	S	S1	S2	S3	S4	S5	H	h	H1
3/4"	20	15	68	68	100	72	135		109	39	78
1"	25	17	81	81	115	82	149		118	43	85

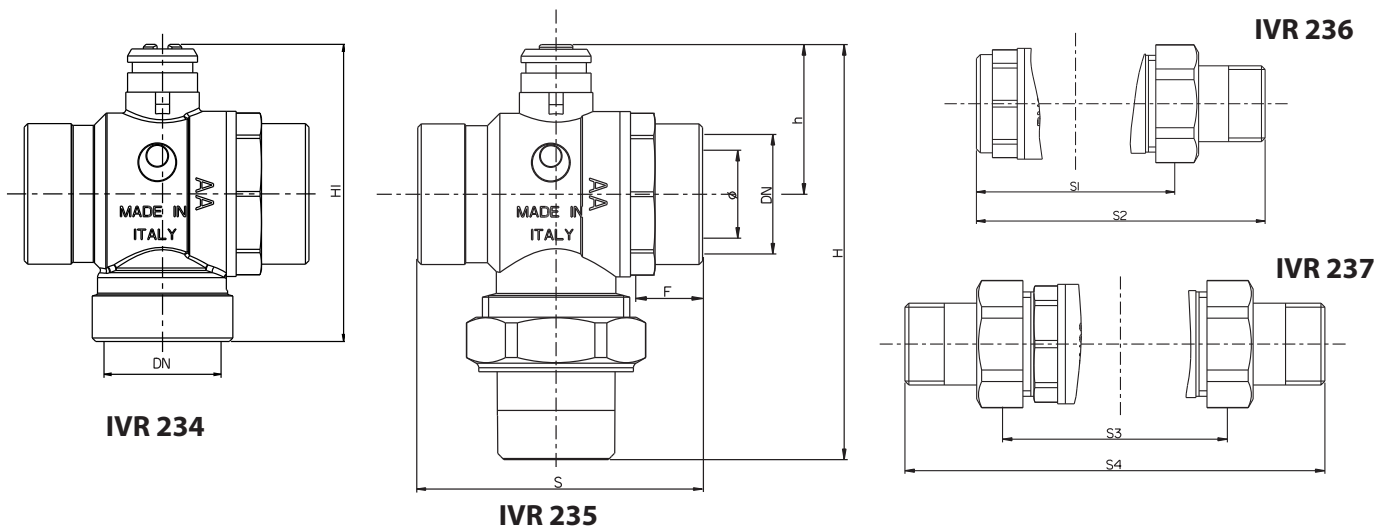

- Motorhead 215 - Uni-Bidirezionale (on-off) - comando a 2 punti con relè - 1 micro supplementare libero in apertura di serie + Compact Motor valvola di zona a 3 vie deviatrice.
- Motorhead 215 - One-Bi directional (on-off) - 2 contact terminals with relay - 1 auxiliary micro-switch free on opening included + Compact Motor 3 ways diverter zone valve.
- Motorhead 215 - Uni-Bidirektional (on-off) - 2-Punkt-Steuerung mit Relais - 1 zusätzlichen Mikroschalter + Compact Motor 3-Wege-Ableitzonenventil.
- Motorhead 215 - Uni-bidirectionnel (on-off) - commande à 2 points avec relais- 1 micro supplémentaire + Compact Motor vanne de zone à 3 voies déviateur.
- Электропривод Motorhead 215 - Одно-двухпозиционный (on-off) - 2 контактных зажима с реле - 1 вспомогательный микровыключатель + Compact Motor трехходовый клапан распределитель.

DIMENSIONI - DIMENSIONS (mm)

Size	Ø	H	h	H1	h1
3/4"	20	167	97	137	98
1"	25	176	101	143	101

